

Drive solutions for wastewater treatment

Complete drive solutions from a single source



DRIVESYSTEMS

Our Solution. Your Success.

Complete drive solutions from a single source



NORD delivers

NORD offers first-class customer service and support along with full-featured drive solutions that can tackle the toughest requirements. All components are carefully selected and precisely configured to meet your exact specifications. In the rare case that standard components won't meet your needs, our in-house engineering team will work with you to design custom components or a complete customized system.

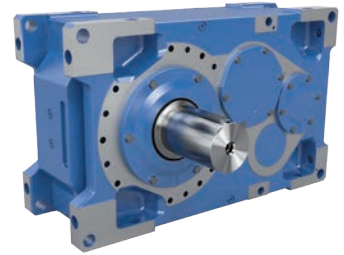

Reduce lead times and decrease inventory

- ▶ Fastest lead times in the industry with NO expedite fees
- ▶ Over 20,000,000 standard configurations to reduce or eliminate the need for custom components
- ▶ Modular drives, motors, and electronic controls minimize inventory of replacement units and parts



Global product designs, standards, and support

- ▶ Innovative, industry-standard products to support a wide range of applications
- ▶ Global sales and support network
- ▶ Dedicated mechanical and electrical application engineers ready to assist you
- ▶ Online resources available to you any time
- ▶ 24/7/365 emergency breakdown service

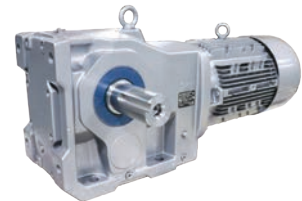

Increase efficiency and reduce operation costs

- ▶ myNORD online tools for fast selection, configuration, ordering, and tracking of your drive units
- ▶ Drive systems that are perfectly matched to your application for optimum performance and energy efficiency
- ▶ Program personalization, such as weekly shipment schedules and custom nameplates
- ▶ Partner with a company that is easy to do business with and wants to see you succeed!





We support you

With years of experience in the wastewater industry, NORD DRIVESYSTEMS creates economical applications that meet all current requirements and prepare you for future system upgrades.

Design

- ▶ myNORD
- ▶ Reduced number of variants
- ▶ Project design / optimization
- ▶ Drive system design
- ▶ Application solutions
- ▶ Green solutions
- ▶ CAD drawings

Commissioning

- ▶ Plug-and-Play
- ▶ Support
- ▶ Training
- ▶ Documentation
- ▶ Smart commissioning

Service

- ▶ Predictive Maintenance (PLC function)
- ▶ Spare parts, express shipping
- ▶ Global presence
- ▶ 24/7/365 support

Drive solutions for the wastewater industry

Aeration

NORD drive systems keep brush and surface aeration systems performing to effectively deliver oxygen into wastewater within municipal lagoons.

Pumps

NORD gear units optimize pump efficiency and prevent backups, keeping systems throughout the plant running smoothly to move water from one process to the next.

Clarifiers

NORD drive systems allow both small- and large-volume water clarifying applications to efficiently separate solid and liquids.

Sludge Thickening

Variable frequency drive technology combines with gearmotors on sludge thickening machines to optimize the speed of the paddles in tanks, efficiently increasing the solid concentration and decreasing the free water.

Screens

Screening is the first step in wastewater processing and is crucial to plant performance. Mechanical cleaning screens automated by NORD gearmotors produce lower labor costs and improve flow conditions and screening capture.

Screw Pumps

Powerful drive systems are needed to pump heavily contaminated liquids that often have solid particulate. NORD gear units provide all of the torque required with seals and surface protection options to ensure longevity.



NORD DRIVESYSTEMS is one of the world's leading drive technology manufacturers. Our industry-specific, innovative drive solutions are used throughout the world for a wide variety of applications in the wastewater treatment industry.

We know your business, precisely understand your requirements, and strive for long-term collaboration with our customers and partners. You can be confident that we will do everything that we can to reinforce the reputation of your brand.



NORD DRIVESYSTEMS provides:

- ▶ Extensive knowledge of applications and technical support
- ▶ Complete drive solutions from a single source
- ▶ Strong global presence and service
- ▶ Thousands of installed drives in wastewater systems
- ▶ Wide range of products with high quality standards
- ▶ Great reliability, economy, and service life
- ▶ Recognized product quality compliant with international standards

Drive solutions for the wastewater industry

Complete Support Before and After the Sale

NORD DRIVESYSTEMS designs, engineers, and manufactures scalable drive solutions for all segments of the wastewater treatment industry. Our drive solutions are efficient, reliable, and highly-specialized for precise application needs.

Drive solutions for:

- ▶ Brush aerators
- ▶ Surface aerators
- ▶ Clarifier tanks
- ▶ Pumps
- ▶ Aerated grit chambers
- ▶ Agitators and mixers
- ▶ Air flotation systems
- ▶ Screw pumps



Screens

NORD's robust, cost-effective gear units deliver high efficiency performance to keep screening machines running effectively.

- ▶ IP66 protection
- ▶ UNICASE one-piece housings
- ▶ Long life, low maintenance
- ▶ Compact design



Pumps

NORD's energy-efficient gear units, motors, and variable frequency drives ensure top reliability to keep energy costs low.

- ▶ IP66 ingress protection
- ▶ Corrosion resistant with high-quality surface protection options
- ▶ Advanced QUADRALIP™ sealing system to prevent leaks
- ▶ Dual shaft sealing rings



Clarifiers

Clarification systems using NORD drive units operate more efficiently with less downtime, resulting in more clean, effluent water and overall better plant production.

- ▶ Wide range of surface treatment options for added protection
- ▶ Corrosion resistant shaft material
- ▶ Energy-efficient drives to reduce costs

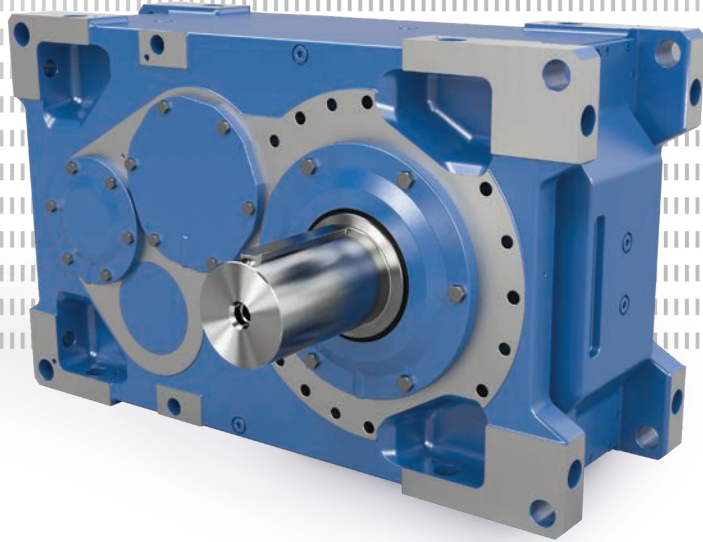

Screw Pumps

NORD's robust gear units can handle the high flow rates and heavily contaminated liquids moved by screw pumps.

- ▶ Torque range up to 2,495,900 lb-in
- ▶ Flexible mounting solutions
- ▶ High-performance sealing systems
- ▶ Variety of surface treatment options



Aeration

Brush and surface aerator drives from NORD require little to no preventative maintenance.

- ▶ UNICASE compact housing
- ▶ Special output cover design to help protect oil seals
- ▶ High quality, low friction bearings for long operating life
- ▶ Dual output seals



Sludge Thickening

Equipping variable frequency drives on sludge thickening tanks allows the speed of the vertical paddles to be controlled by the drive. The speed can be adjusted at any point to fit the application.

- ▶ Robust design for long life, low maintenance
- ▶ Integrated PLC function
- ▶ Reinforced output shaft extensions

Drive solutions for the wastewater industry



Efficient, safe, and proven drive solutions from a single source

Efficient

NORD drive solutions are environmentally friendly and fulfill all current national and international energy saving standards.

- ▶ Lightweight aluminium or cast iron construction
- ▶ NORD motors for all requirements, including IE3, IE4, and IE5+
- ▶ Intelligent NORD variable frequency drives with energy saving flux reduction for optimal operation under partial load or low speeds.

Reliable

From pinions to circuit boards, all NORD mechatronic components are produced in our own factories, which means unsurpassed reliability, long service life, and low Total Cost of Ownership (TCO). Countless options can be configured for all requirements of the wastewater treatment industry.

- ▶ UNICASE™ housings ensure precise positioning of bearings and shafts
- ▶ AUTOVENT™ ensures a leak free operation
- ▶ Protection class IP66 or IP69K
- ▶ Biodegradable oils available
- ▶ Moisture, rust, and dust protection
(See the S3400 Surface Protection flyer for more information).

Tried and tested

The reliability and cost-effectiveness of NORD drive solutions have proven themselves in the wastewater industry throughout the world.

- ▶ Various options for reinforcing output shafts
- ▶ Increased bearing spacing available as an option to reduce bearing loads, extending service life
- ▶ Corrosion-resistant shaft material

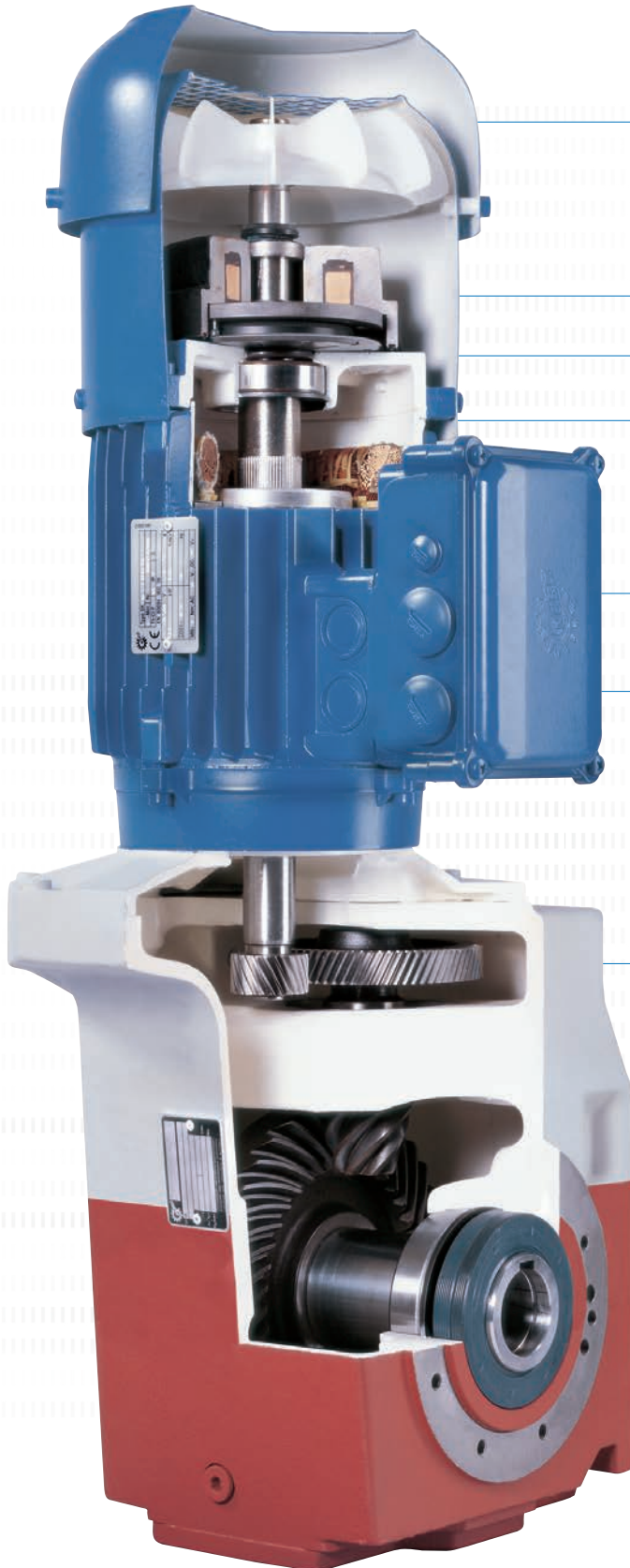

Double cover

IP66 brake

IP66 motor protection class

ICP (Internal Corrosion Protection)

Stainless steel type plate

Potted terminal box (optional)

Increased corrosion protection
through multiple coat painting

Stainless steel shaft available

Available Seal Options

- ▶ Double Seal (NBR or FKM)
- ▶ Taconite
- ▶ Labyrinth
- ▶ Mechanical

Drive solutions for the wastewater industry

Components for Ultimate Protection

NORD offers reinforced outputs designed to handle high radial loads while keeping the bearing cavity dry and free from contaminants. There are four different levels of protection that are available beyond our standard offering.

VL2 Reinforced Spread Design Drive Shaft Bearings

- ▶ Specially designed output bearings for agitator and mixer applications requiring increased bearing load capacities
- ▶ Increased bearing spacing provides maximum radial and axial load capacity
- ▶ Lower bearing is an oversized, double row spherical bearing that absorbs high overhung and thrust loads and compensates for alignment errors in long agitator shafts
- ▶ Includes grease fitting for the lower bearing and a removeable plug to allow excess grease to purge from the bearing cavity
- ▶ Only for MAXXDRIVE units

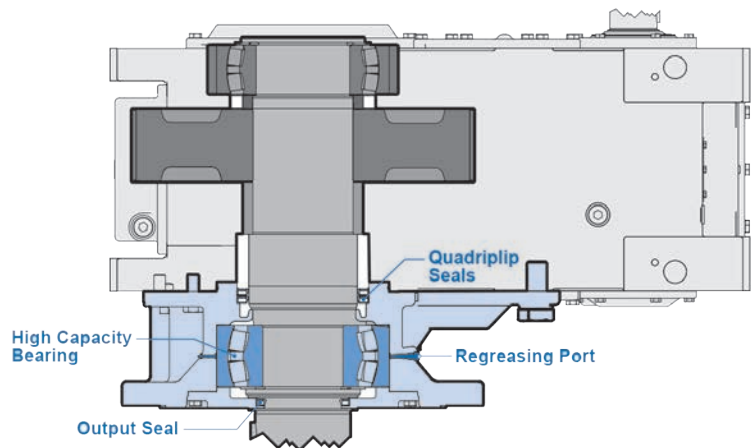

VL3 Spread Design with Oil-Safe Dry Cavity

- ▶ VL2 design with added oil drip tray contour on the flange
- ▶ Includes an oil leakage detection port to enable early detection of wear on the seals between the grease cavity and the main oil chamber
- ▶ If oil leaks past the reducer seals, it flows down to the oil slinger mounted onto the shaft
- ▶ As the shaft rotates, oil will sling off into the dry cavity and is shown by an oil indicator. An electrical oil sensor is also available
- ▶ M5 mounting position only for MAXXDRIVE units

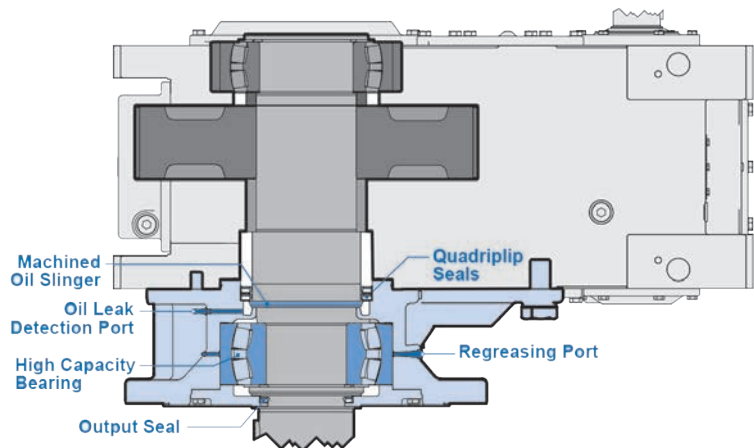

VL4 Spread Design with True Drywell

- ▶ VL3 design with additional oil leak protection measures
- ▶ QUADRALIP seals are replaced with a standpipe that has additional sealing including a V-ring seal and multiple O ring seals
- ▶ Prevents the risk of leakage with downward facing output shafts
- ▶ No rubbing seals below the oil level
- ▶ Available for bevel gear, parallel shaft gear units
- ▶ Hollow shaft version with shrink disc, optionally with push-in shaft
- ▶ Only for MAXXDRIIVE units

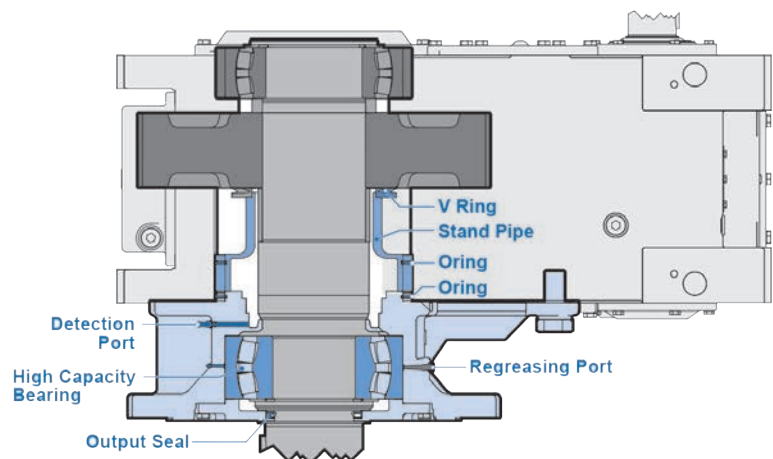

VL6 Spread Design with True Drywell (No Flange)

- ▶ Includes all internal VL4 design elements housed by a bolt-on, non-flanged cover
- ▶ Only for MAXXDRIIVE units

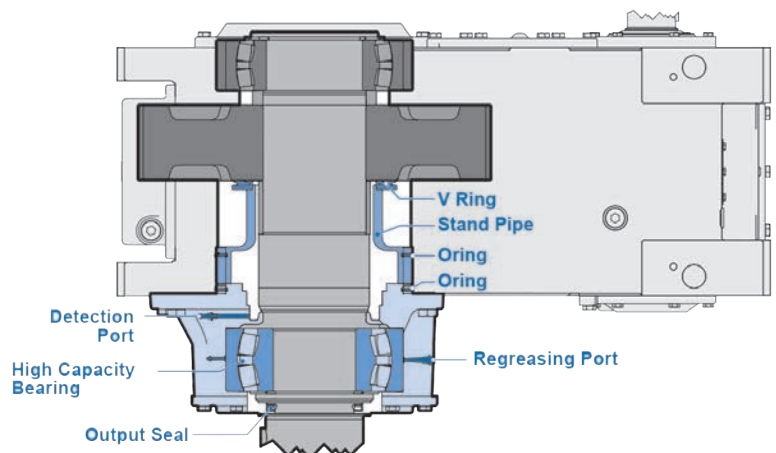

Drive solutions for the wastewater industry

Optimized Sealing Systems

NORD gear units feature an advanced sealing system designed to meet the most stringent requirements. Each input shaft is equipped with a reliable radial FKM sealing ring and gamma ring as a standard, ensuring an advanced level of dust protection and maximizing service life.

The sealing points on the output shaft are equipped with double sealing rings for enhanced performance. This combination includes an inner sealing ring (Type A), typically accompanied by an outer seal featuring a dust protection lip design (Type AS). The default output seal material is NBR (Buna N), with the option for FKM/Viton (Fluoroelastomer) as an alternative. When operating oil temperatures exceed 85°C / 185°F, FKM seals are the standard configuration.

In addition to NORD's standard seals, additional sealing configurations are available, including

- ▶ Taconite sealing systems for input shaft and output shaft
- ▶ DRYWELL sealing in combination with VL3/KL3
- ▶ TRUE DRYWELL as standalone sealing option or as an integral part of the output designs (VL4/KL4 and VL6/KL6 available for MAXXDRIVE units)

Double Shaft Sealing Rings

- ▶ Optimum sealing
- ▶ Long life gasket
- ▶ Clean gear oil

FKM Material

- ▶ Resistant to chemicals and high temperatures
- ▶ Consistent performance over a wide range of applications

Labyrinth Seals

- ▶ Re-greaseable / non-re-greaseable versions
- ▶ Protects against splashed water and dirt

Mechanical Seal

- ▶ For contact with aggressive and contaminated liquids
- ▶ For use with underwater drive units

For more specific requirements, dedicated sealing systems can be applied on a case-by-case basis, e.g., metal face sealings (mechanical seals). Contact NORD for more information.

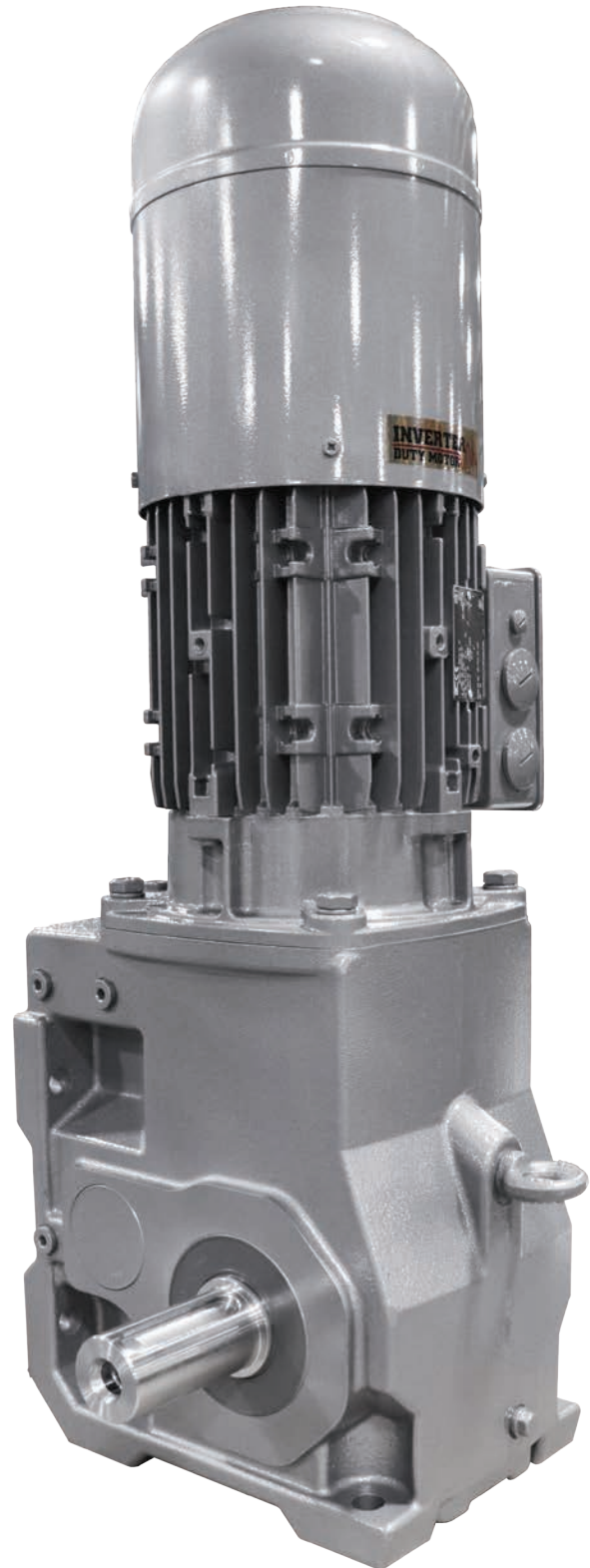

Surface Protection Options

Standard IP55 protection

- ▶ Motor with shaft sealing ring on the B side
- ▶ Electrolytically galvanized fan cover
- ▶ Corrosion resistance
- ▶ Optional high-quality surface protection
- ▶ Stainless friction plates for brakes optional
- ▶ Stainless type plate optional
- ▶ Stainless fastening screws optional

Optional IP66 protection

- ▶ IP66 motor with shaft sealing ring on the B side
- ▶ Electrolytically galvanized fan cover
- ▶ IP66 brake
- ▶ Potted terminal box (optional)
- ▶ Stainless type plate
- ▶ Ball bearing in 2 RS version with sealing discs



Safety Features

Overload Protection

- ▶ Safety coupling installed between the motor and the gear unit, alternatively between two gear units
- ▶ IEC/NEMA standard connection dimensions
- ▶ Backlash-free torque transfer
- ▶ Simple torque setting
- ▶ Integrated sensor
- ▶ Protected in housing

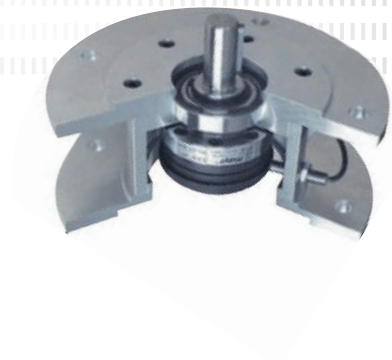

Drive solutions for the wastewater industry



Surface & Brush Aerator Applications

- ▶ MAXXDRIVE or Parallel Shaft Gear Unit
- ▶ High-efficiency electric motor based on the latest international requirements
- ▶ NEMA/IEC adapter
- ▶ Options for vertical and horizontal orientation
- ▶ Advanced sealing system
- ▶ Modular flange and bearing solutions
- ▶ High radial and axial load capacity



Screw Pump Applications

Configuration options:

- ▶ Helical Inline Gear Unit
- ▶ Electric motor based on the latest international requirements
- ▶ NEMA/IEC adapter
- ▶ Advanced sealing system
- ▶ Numerous low ratios available

Drive solutions for the wastewater industry



Mixing & Agitating Applications

Configuration options:

- ▶ MAXXDRIVE or Parallel Shaft Gear Unit
- ▶ High-efficiency electric motor based on the latest international requirements
- ▶ NEMA/IEC adapter
- ▶ Options for vertical and horizontal orientation
- ▶ Advanced sealing system
- ▶ Modular flange and bearing solutions
- ▶ High radial and axial load capacity



Skimmer Applications

Configuration options:

- ▶ Helical Bevel or Parallel Shaft Gear Unit
- ▶ Electric motor based on the latest international requirements
- ▶ NEMA/IEC adapter
- ▶ Advanced sealing system

Drive solutions for the wastewater industry

UNICASE™ helical gear units (Catalog G1000)



- ✓ Foot or flange mounted
- ✓ Long life, low maintenance
- ✓ Closely stepped ratios
- ✓ Cast-iron UNICASE housing

Sizes: 11
Power: 0.16 – 200 hp
Torque: Up to 205,000 lb-in
Ratio: 2.76:1 – 14,340.31:1

Parallel shaft gear units (Catalog G1000)



- ✓ Foot, flange, or shaft mounted
- ✓ Hollow or solid shaft
- ✓ Compact design
- ✓ Cast-iron or aluminum UNICASE housing

Sizes: 15
Power: 0.16 – 200 hp
Torque: Up to 680,000 lb-in
Ratio: 4.03:1 – 15,685.03:1

UNICASE™ bevel gear units (Catalog G1000)



- ✓ Foot, flange, or shaft mounted
- ✓ Hollow or solid shaft
- ✓ Cast-iron UNICASE housing
- ✓ Closely-stepped ratios

Sizes: 11
Power: 0.16 – 200 hp
Torque: Up to 442,500 lb-in
Ratio: 8.04:1 – 13,432.68:1

MAXXDRIVE® industrial gear units (Catalog G1050)

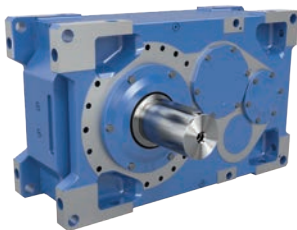

- ✓ Parallel and angled gear units
- ✓ High precision axis alignment
- ✓ Cast-iron UNICASE housing
- ✓ Long life, low maintenance

Sizes: 11
Power: 2.5 – 8,075 hp
Torque: 132,800– 2,495,900 lb-in
Ratio: 5.60:1 – 30,000:1

NORDAC® FLEX SK 200E variable frequency drives (Catalog E3000)



- ✓ Energy saving function
- ✓ Integrated POSICON positioning control
- ✓ Integrated PLC

Sizes: 4
Voltage: 1~ 110 – 120 V, 1~ 200 – 240 V, 3~ 200 – 240 V, 3~ 380 – 500 V
Power: 0.33 – 30 hp

VL bearings

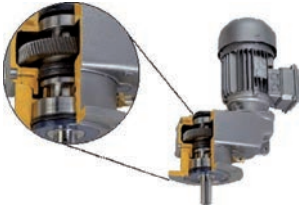

VL II reinforced drive shaft bearings

- ✓ Large bearing spacing + reinforced bearings = maximum radial and axial load capacity
- ✓ Longer service life

VL III DRYWELL

- ✓ Additional oil drip plate
- ✓ Oil leak detector or oil sensor

VL IV TRUE DRYWELL

Prevents the risk of leakage with downward-facing output shafts

- ✓ No rubbing seals below the oil level
- ✓ Available for bevel gear and parallel shaft gear units
- ✓ Hollow shaft version with shrink disc, optionally with mit push-in shaft

Overload protection



- ✓ Safety coupling installed between the motor and the gear unit, alternatively between two gear units
- ✓ IEC / NEMA connection dimensions
- ✓ Backlash-free torque transfer
- ✓ Simple torque setting
- ✓ Integrated sensor
- ✓ Protected in housing

Various sealing systems and shaft material options



Double shaft sealing rings

- ✓ Optimum sealing
- ✓ Long life gasket
- ✓ Clean gear oil

FKM Material

- ✓ Resistant to chemicals
- ✓ High temperatures

Labyrinth seals

- ✓ Re-greaseable with low maintenance or non-re-greaseable versions
- ✓ Protects against splashed water and dirt

Mechanical seal

- ✓ For contact with aggressive and contaminated liquids
- ✓ For use with underwater drive units

Sealing system prevents leakage with downward-facing output shafts

- ✓ TRUE DRYWELL

Rust-proof shafts

Outdoor motor installation



IP55 protection class as standard

- ✓ IP55 motor with shaft sealing ring on the B side
- ✓ Electrolytically galvanized fan cover
- ✓ IP55 brake and brake drive made from corrosion-resistant material
- ✓ Special painting (optional)
- ✓ Stainless friction plates for brakes (optional)
- ✓ Stainless type plate (optional)
- ✓ Stainless fastening screws (optional)

IP66 option

- ✓ IP66 motor with shaft sealing ring on the B side
- ✓ Electrolytically galvanized fan cover
- ✓ Potted terminal box
- ✓ Stainless type plate
- ✓ Ball bearing in 2 RS version with sealing discs
- ✓ IP66 brake

Ordering is Easy With myNORD Online Tools!

- ▶ Obtain drawing files direct from quote configuration
- ▶ Effortlessly select & configure customized drive solutions
- ▶ Create quotes with account-specific net pricing
- ▶ Order-specific documentation
- ▶ 24/7/365 order tracking
- ▶ Select and order spare parts



Register now at myNORD.com!



US

Central Region
Corporate Headquarters
800 NORD Drive
Waunakee, WI 53597
Tel. 888.314.6673
info.us@nord.com
www.nord.com

East Region
300E Forsyth Hall Dr.
Charlotte, NC 28273
Tel. 888.314.6673
info.us@nord.com

West Region
1180 Railroad St.
Corona, CA 92882
Tel. 888.314.6673
info.us@nord.com

South Region
350 Cypress Hill Dr, Suite 400
McKinney, TX 75071
Tel. 888.314.6673
info.us@nord.com

CA

NORD Gear Limited
Brampton, ON
41 West Drive
Brampton, ON L6T4A1
Tel. 800.668.4378
info.ca@nord.com

MX

NORD DRIVE SYSTEMS SA DE CV
Queretaro, Mexico
Av. Industria Textil B.6
Parque Industrial PYME, Huimilpan
QRO - Mexico 76950
Tel. 52 442 688 7110
info.mx@nord.com